

1

2

3

4

5

6

A

A

B

B

C

C

D

D

5/8-11 THREAD x 1-1/8 DEEP
C'BORE Ø.642 x .300 DEEP

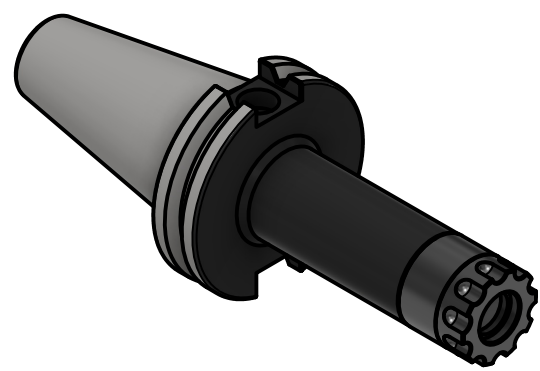
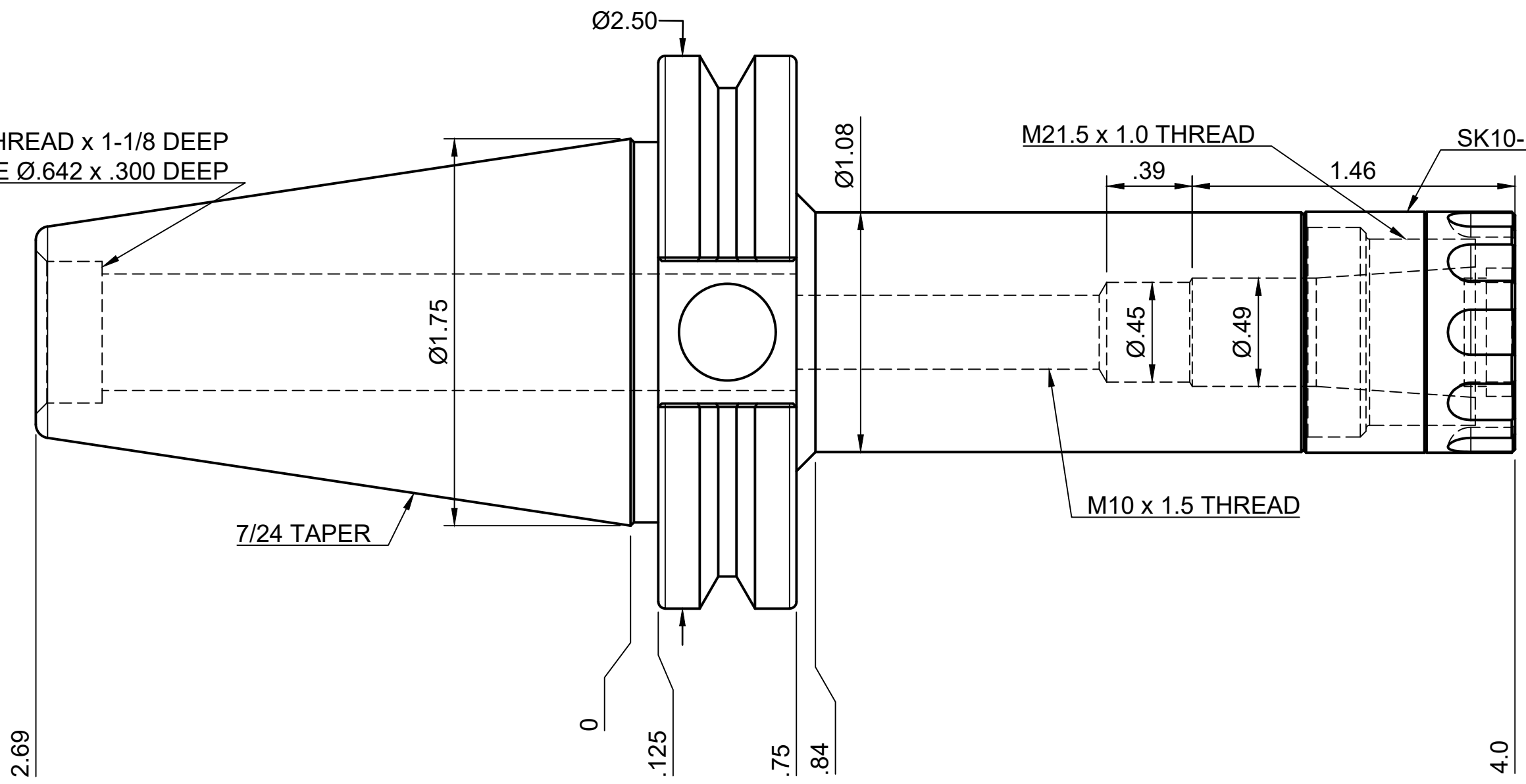

NOTES:
 TAKES ALL SK10 COLLETS FROM .0591"-.3937"
 USES WRENCH PART # HT10-TWA TORQUE WRENCH (NOT INCLUDED)
 FOR MORE PRODUCT DETAILS PLEASE GO TO MARITOO.COM
 AND SEARCH ITEM # LISTED ON THIS PRINT

| | |
|---------------------------|--------------------------|
| MARITOO | |
| www.maritool.com | |
| ITEM# | CAT40-SK10-4.0-HT |
| Made In USA / Drawn By FM | |

1

2

3

4

5

6