

1

2

3

4

5

6

A

A

B

B

C

C

D

D

M12x1.75 THREAD x 1.00 DEEP
C'BORE DIA .494 x .240 DEEP

PRECISION GROUND
FOR DUAL CONTACT FIT

Ø1.81

Ø1.25

Ø.750

Ø4mm

TIP Ø.53

7/24 TAPER

1.91

0

.04

.87

1.45

2.25

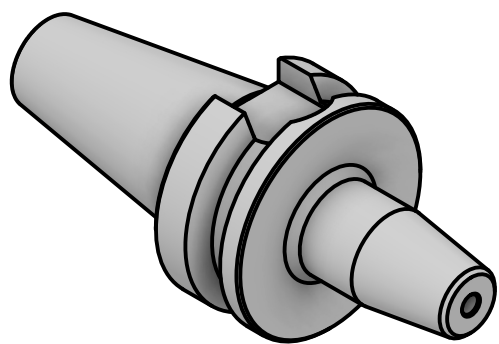

NOTES:
WORKS ON ALL BT30 MACHINES WITH DUAL CONTACT SPINDLES
COMPATIBLE WITH BIG-PLUS® SPINDLES
ACCEPTS 4mm SHANK TOOLING
FOR MORE PRODUCT DETAILS PLEASE GO TO MARITool.COM
AND SEARCH ITEM # LISTED ON THIS PRINT

MARITool

www.maritool.com

ITEM# **BT30-SF4-2.25D**

Made In USA / Drawn By FM

1

2

3

4

5

6