

5/8-11 THREAD x 1-1/8 DEEP
Ø.642 C'BORE x .300 DEEP

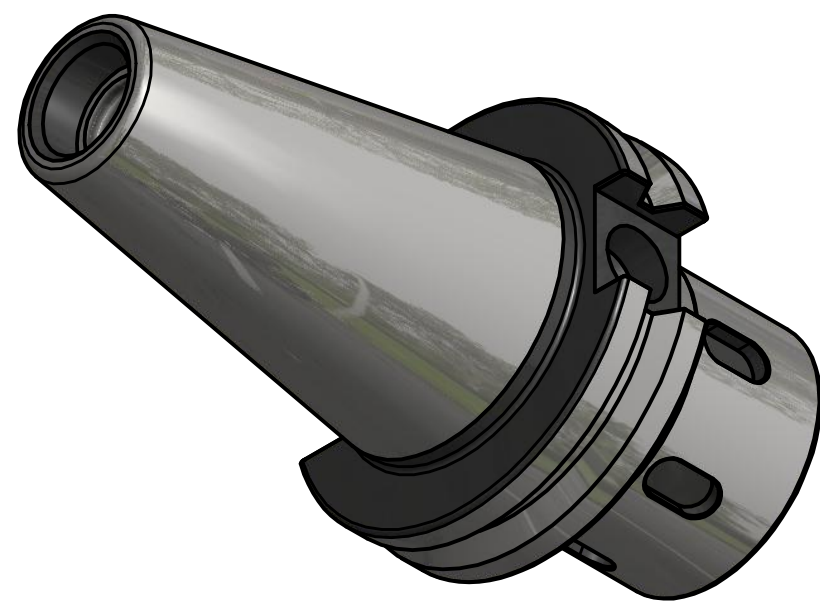
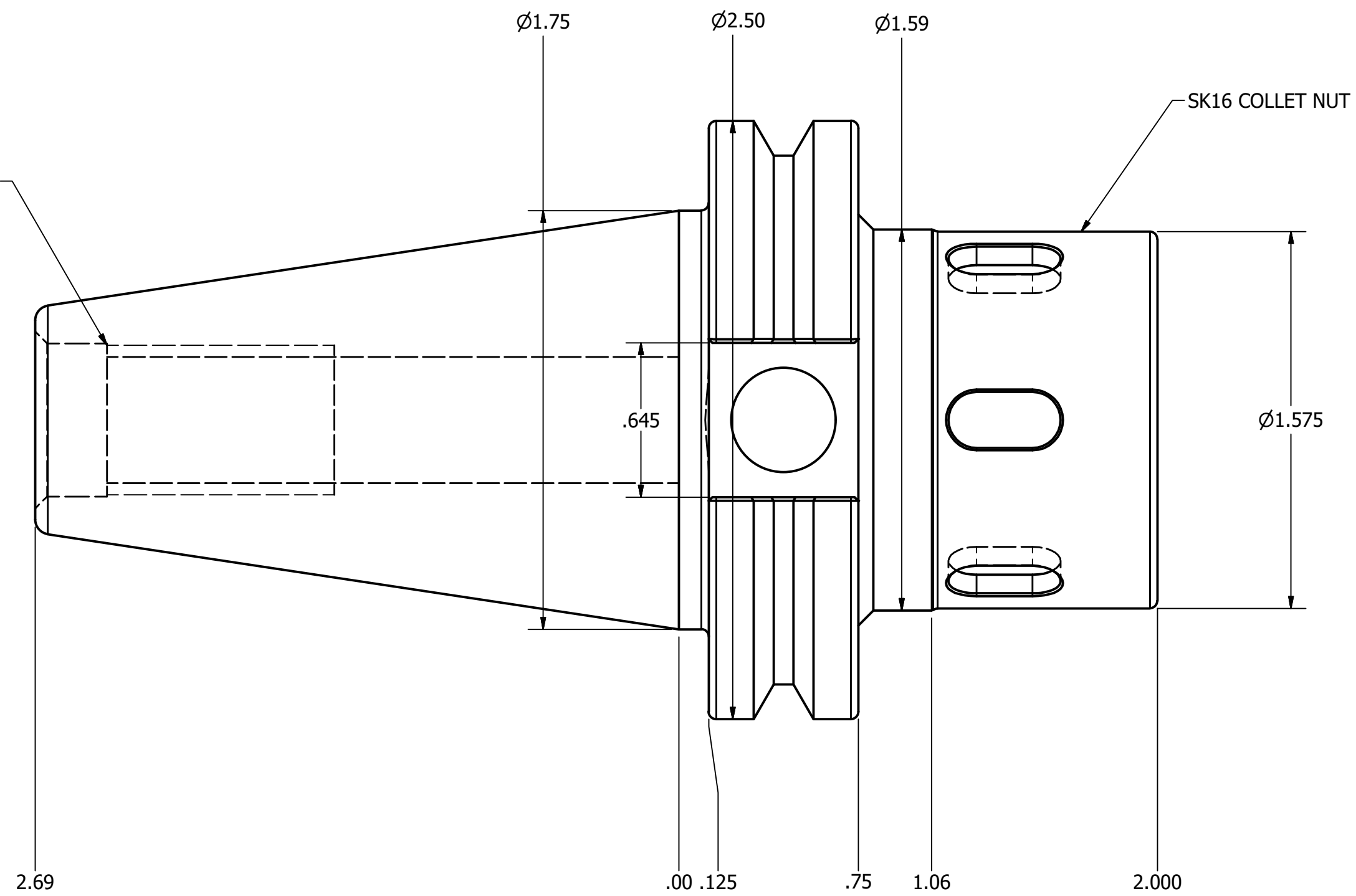

NOTES:
TAKES ALL SK16 COLLETS FROM .09"-.630"
USES WRENCH PART #ER25-BWRENCH (NOT INCLUDED)
FOR MORE PRODUCT DETAILS PLEASE GO TO MARITOO.COM
AND SEARCH ITEM # LISTED ON THIS PRINT

MARITOO

www.maritool.com

ITEM# **CAT40-SK16-2.0**

Made in USA