

1

2

3

4

5

6

A

B

C

D

A

B

C

D

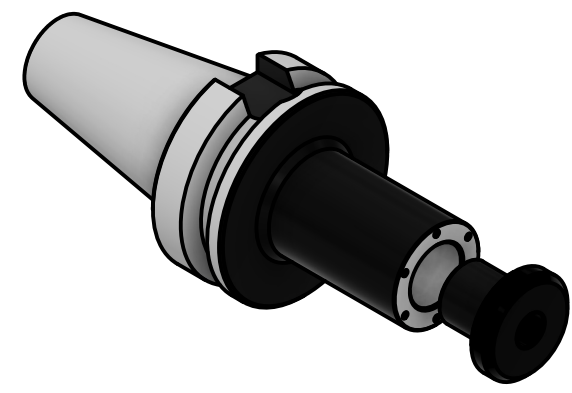
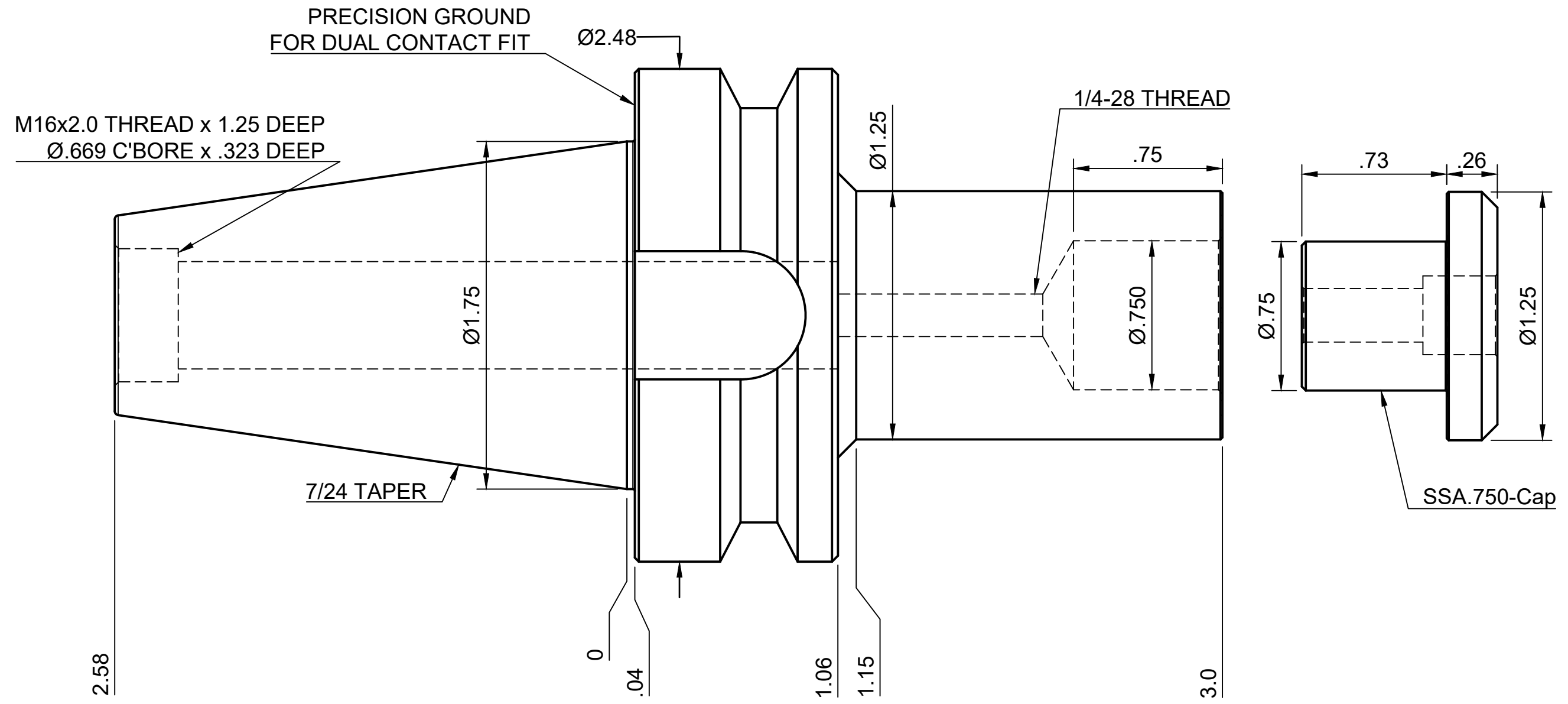

NOTES:  
 WORKS ON ALL BT40 MACHINES WITH DUAL CONTACT SPINDLES  
 COMPATIBLE WITH BIG-PLUS® SPINDLES  
 HOLDER USES LOCK SCREW 1/4-28 x 1-1/4 SHCS (INCLUDED)  
 ACCEPTS SAWS WITH Ø.750 ARBOR HOLE  
 FOR MORE PRODUCT DETAILS PLEASE GO TO MARITool.COM  
 AND SEARCH ITEM # LISTED ON THIS PRINT

<b>MARITool</b>	
<a href="http://www.maritool.com">www.maritool.com</a>	
ITEM#	<b>BT40-SSA.750-3.0D</b>
Made In USA / Drawn By FM	

1

2

3

4

5

6