

1

2

3

4

5

6

A

A

B

B

C

C

D

D

M22 x 2.0 REAR THREAD FOR
OPTIONAL COOLANT PLUG (NOT INCLUDED)

Ø1.250 SHANK

Ø1.535

1.375 CUTTING
DIAMETER

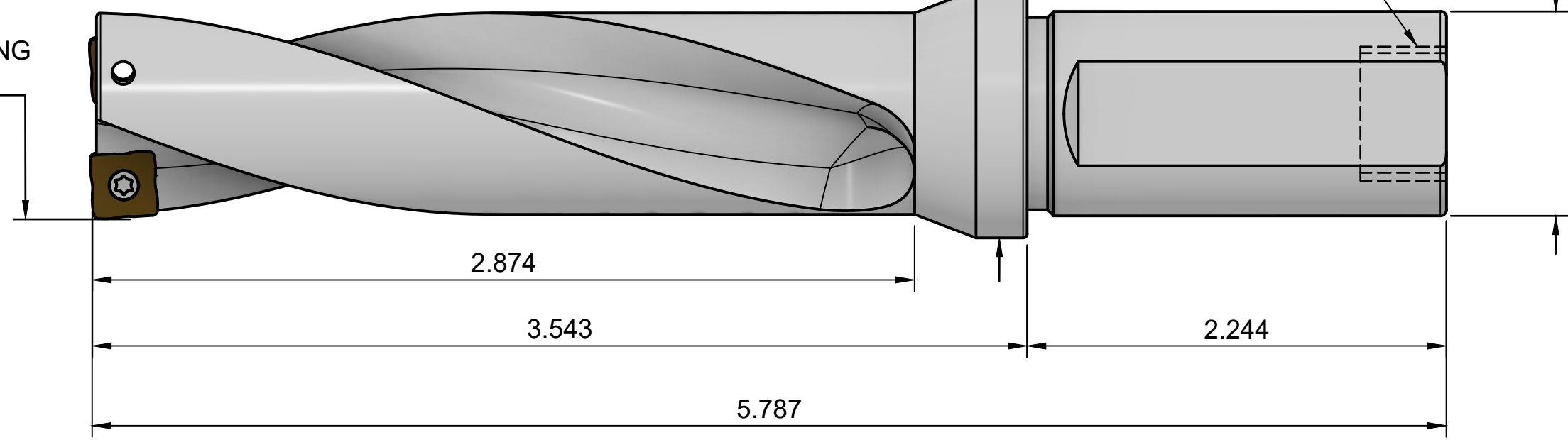

NOTES:
 DRILL BODY TAKES SOMT011.... INSERTS (INSERTS NOT INCLUDED)
 AFTER DRILLING HOLE, OUTER INSERT CAN BE OFFSET AND USED AS A
 BORING BAR
 FOR SPEEDS AND FEEDS PLEASE VISIT PRODUCT DETAILS PAGE
 AND SEARCH ITEM # LISTED ON THIS PRINT

MARITool	
www.maritool.com	
ITEM#	FBD-1375-2D-1U
Drawn By FM	

1

2

3

4

5

6