

1

2

3

4

5

6

A

A

B

B

C

C

D

D

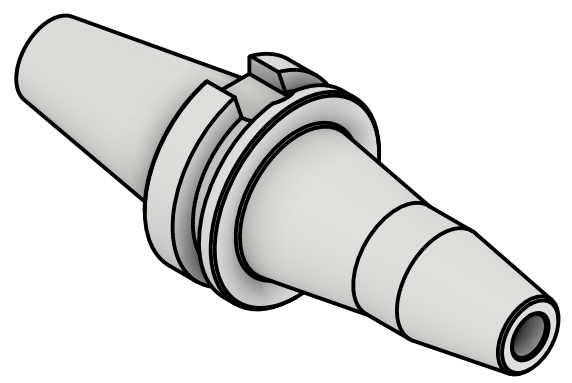
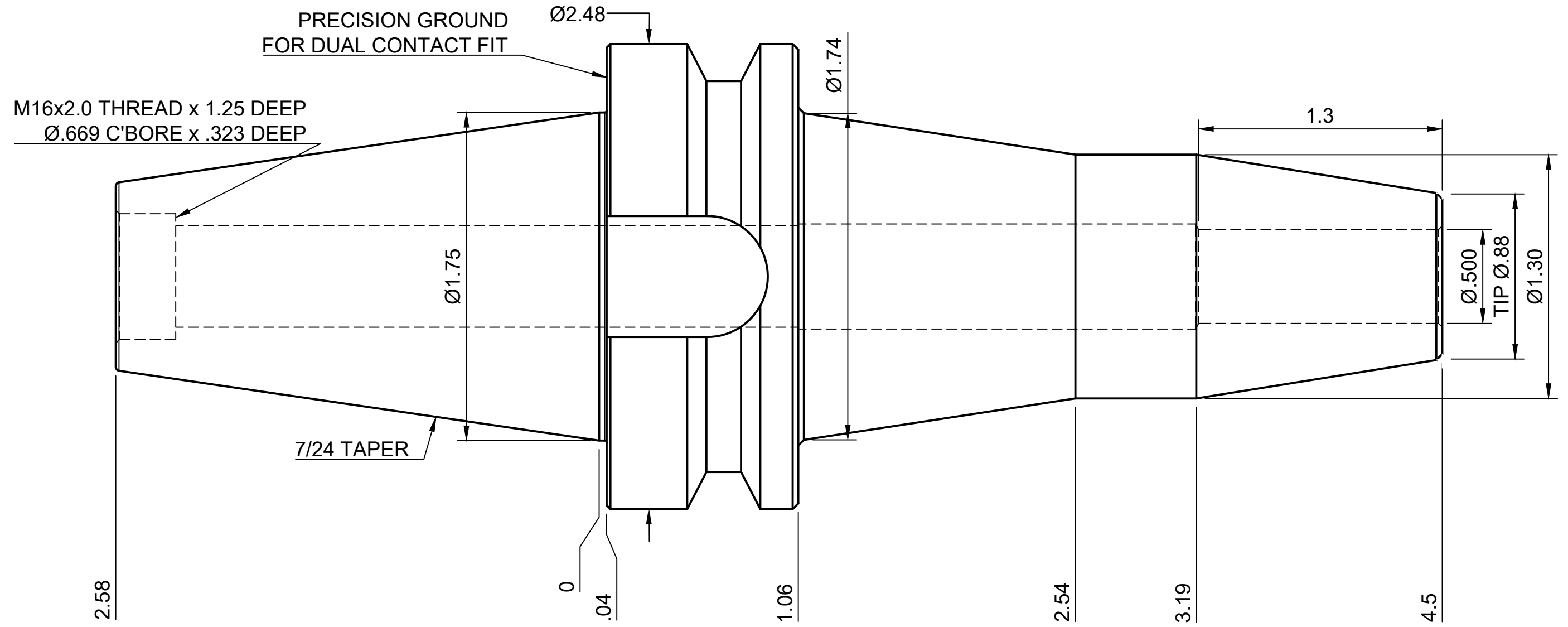

NOTES:
 WORKS ON ALL BT40 MACHINES WITH DUAL CONTACT SPINDLES
 COMPATIBLE WITH BIG-PLUS® SPINDLES
 ACCEPTS 0.500 SHANK TOOLING
 FOR MORE PRODUCT DETAILS PLEASE GO TO MARITool.COM
 AND SEARCH ITEM # LISTED ON THIS PRINT

MARITool	
www.maritool.com	
ITEM#	BT40-SF.500-4.5DT
Made In USA / Drawn By FM	

1

2

3

4

5

6