

4

3

2

1

D

D

C

C

B

B

A

A

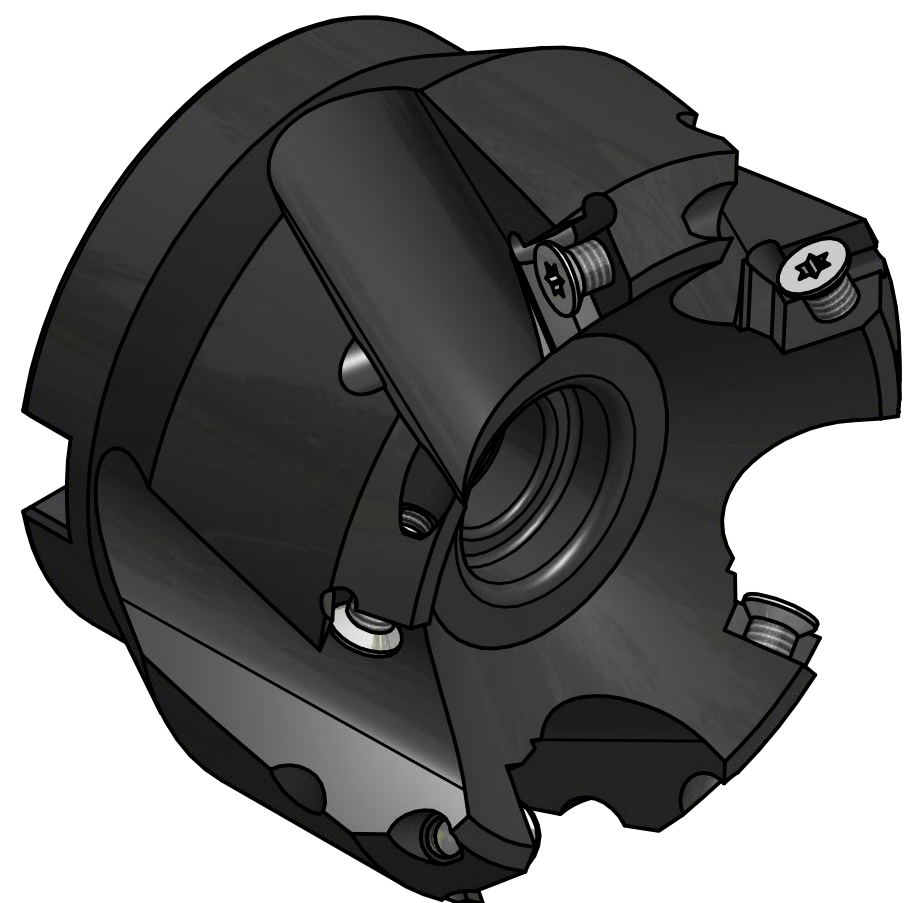
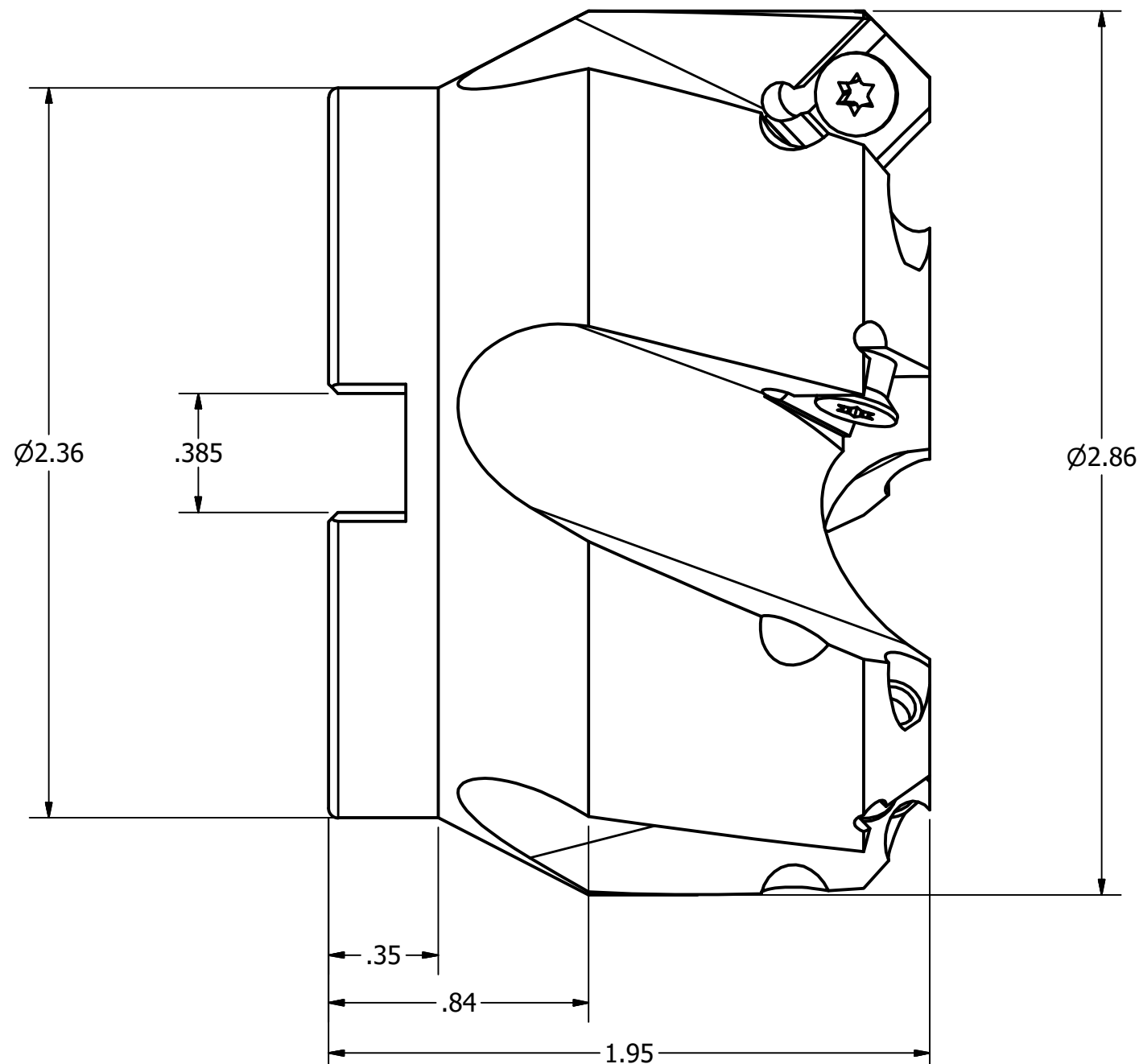

**NOTES:**

- 5 flute indexable shell mill 2.48 inch (63mm) cutting diameter at tip
- This cutter is 2.0 inches tall
- 1.00 inch arbor hole
- 2.86 inch largest body diameter
- All critical surfaces precision ground
- Made from alloy steel for excellent vibration control
- Torx wrench and insert screws are included
- Inserts are not included but available (SEHW1204AFTN or similar)
- Insert size is .5 inches square X .187 thick X 20 deg side clearance X .218 hole
- Insert pockets are precision machined to maintain perfect concentricity
- Inserts can be indexed 4 times in this cutter

FOR MORE PRODUCT DETAILS PLEASE GO TO [MARITool.COM](http://MARITool.COM)  
AND SEARCH ITEM # LISTED ON THIS PRINT

**MARITool**

[www.maritool.com](http://www.maritool.com)

ITEM# **F45SE12-D063A05Rx1**

4

3

2

1