

NOTES:  
 WORKS ON ALL CAPTO® C4 MACHINES  
 TAKES ALL ER16 COLLETS FROM .039"-.4375"  
 USES WRENCH PART # ER16-WRENCH (NOT INCLUDED)  
 FOR MORE PRODUCT DETAILS PLEASE GO TO MARITOO.COM  
 AND SEARCH ITEM # LISTED ON THIS PRINT

PSC4 is referred to as C4 and both are compatible.  
 \*Capto is trademark of Coromant Capto® and Sandvik Coromant and is  
 used only for identification purposes.  
 Compatible with C4 spindles, but not licensed.

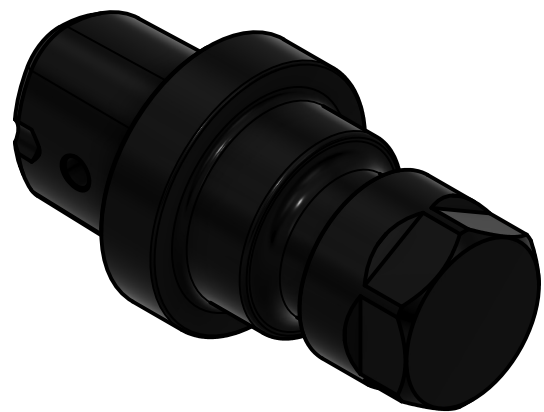

**MARITOO**

www.maritool.com

ITEM# **PSC4-ER16-50W**

Drawn By FM